



Motorcycle

Scooter

ATV

Personal Watercraft

UTV

LITHIUM

# HYPER SPORT

## PAL16HY 12.8V 115W/Hr CA 270A

Lithium Iron Phosphate (LiFePO4) Battery  
Hyper Sport Series

### TERMINALS: (mm)

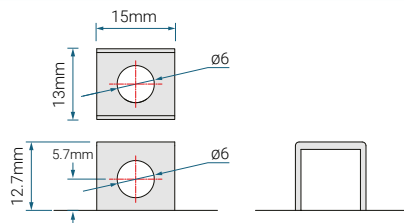

### DIMENSIONS: inch (mm)

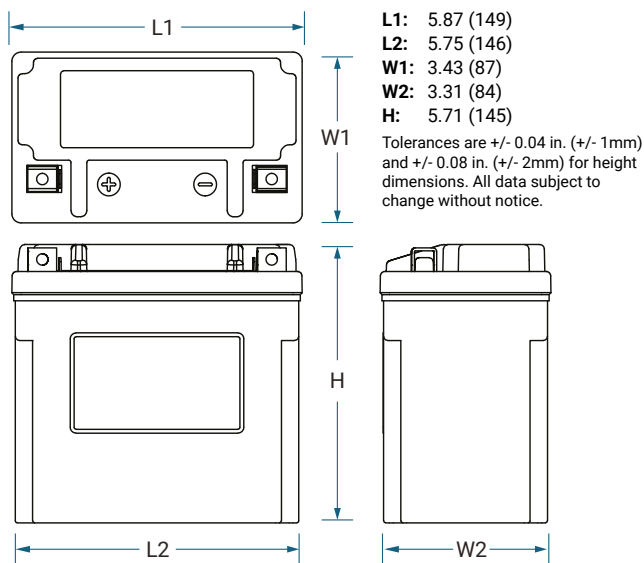

### CORPORATE HEADQUARTERS (USA AND INTERNATIONAL EXCLUDING EMEA)

**Power-Sonic Corporation**  
7550 Panasonic Way, San Diego,  
California 92154  
T: +1 (619) 661 2020  
F: +1 (619) 661 3650  
E: customer-service@power-sonic.com

### POWER-SONIC EUROPE LIMITED (EMEA – EUROPE, MIDDLE EAST AND AFRICA)

3 Buckingham Square,  
Hurricane Way, Wickford,  
Essex SS11 8YQ  
T: +44 (0)1268 560686  
F: +44 (0)1268 560902  
E: salesEMEA@power-sonic.com



HYPER SPORT  
SERIES



### GO SMARTER

Active intelligent monitoring. At The heart of every Hyper Sport Lithium battery is an integrated management system that monitors and reacts to multiple voltage, current, and temperature events to maximize performance, battery life and safety.

### GO SAFER

Lithium Iron Phosphate (LiFePO4) is the safest type of lithium battery and a ready to go replacement and upgrade from lead acid, AGM or gel.

### GO FASTER

### GO LONGER

- 4X lighter
- 4X longer life
- 4X faster charge time
- 4X the warranty

### GO HYPER SPORT

Simply connect your battery and you are ready to go.

### PERFORMANCE SPECIFICATIONS

<b>Nominal Voltage</b>	12.8V
<b>Watt-Hour (4.5A to 10.0 volts)</b>	115
<b>Charging Voltage</b>	14.4V (Standard) – 14.8V (Max)
<b>Charging Current</b>	4.5A (Standard) - 18.0A (Max)
<b>Approximate Weight</b>	3.3 lbs. (1.5kg)
<b>Max continuous output current</b>	27A
<b>Max starting current (5s at 77°F (25°C))</b>	270A
<b>Cycle life (80% DOD at 77°F (25°C))</b>	≥2000
<b>Charge Retention (Shelf Life) (at 68°F (20°C))</b>	
1 Month	≥95%
3 Month	≥90%
6 Month	≥80%
<b>Operating Temperature Range</b>	
Charge and Discharge	14°F (-10°C) to 131°F (55°C)
Storage	-4°F (-20°C) to 104°F (40°C)
<b>Case</b>	ABS
<b>Upgrade to lead acid battery model</b>	PTX14-BS, PTX14BS-FS, PTX16-BS

# HYPER SPORT

GO SMARTER · GO SAFER · GO FASTER · GO LONGER

## PAL16HY 12.8V 115W/Hr CA 270A

Lithium Iron Phosphate (LiFePO4) Battery  
Hyper Sport Series

### DISCHARGE TIME VS DISCHARGE CURRENT (25°C)

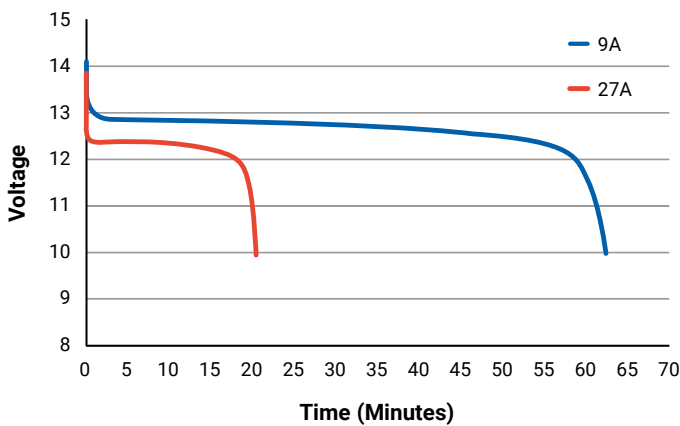

### PULSE DISCHARGE CURVE (10 SECONDS)

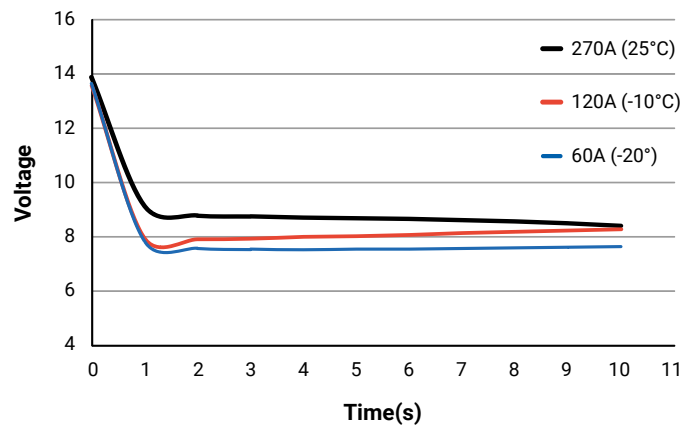

## CHARGING

The battery can be used if the voltage is higher or equal to 12.8V, although we recommend fully charging the battery if the voltage is below 13.0V. Apply constant voltage charge between 14.0V and 15.0V to fully charge the battery.

The Hyper Sport series requires lithium compatible chargers and testers. We do not recommend the use of lead acid chargers as many in the market are not suitable for lithium iron phosphate batteries.

## APPLICATIONS

- Motorcycle
- Scooter
- ATV
- Watersport
- UTV

## WARRANTY

Designed and engineered at our ISO 9001:2001 certified factories all Power Sonic batteries are subject to stringent quality control through every step of the manufacturing process ensuring both consistency and reliability. The Hyper Sport series are backed by a 2-year limited warranty.



## FURTHER INFORMATION

Please refer to our website [www.power-sonic.com](http://www.power-sonic.com) for a complete range of useful tools and downloads, such as our PowerSports battery finder, application guides, material safety datasheets and much more.

### CORPORATE HEADQUARTERS (USA AND INTERNATIONAL EXCLUDING EMEA)

**Power-Sonic Corporation**  
7550 Panasonic Way, San Diego,  
California 92154  
T: +1 (619) 661 2020  
F: +1 (619) 661 3650  
E: [customer-service@power-sonic.com](mailto:customer-service@power-sonic.com)

### POWER-SONIC EUROPE LIMITED (EMEA – EUROPE, MIDDLE EAST AND AFRICA)

3 Buckingham Square,  
Hurricane Way, Wickford,  
Essex SS11 8YQ  
T: +44 (0)1268 560686  
F: +44 (0)1268 560902  
E: [salesEMEA@power-sonic.com](mailto:salesEMEA@power-sonic.com)